





Circle Group,

providing innovative technological solutions for the automation and digitalisation of the entire supply chain

delivering high value consultancy services supporting maritime, port and logistics actors to gather EU funding and promoting their strategic visibility at international level



*Is the right international partner for your smart, sustainable and effective business growth*

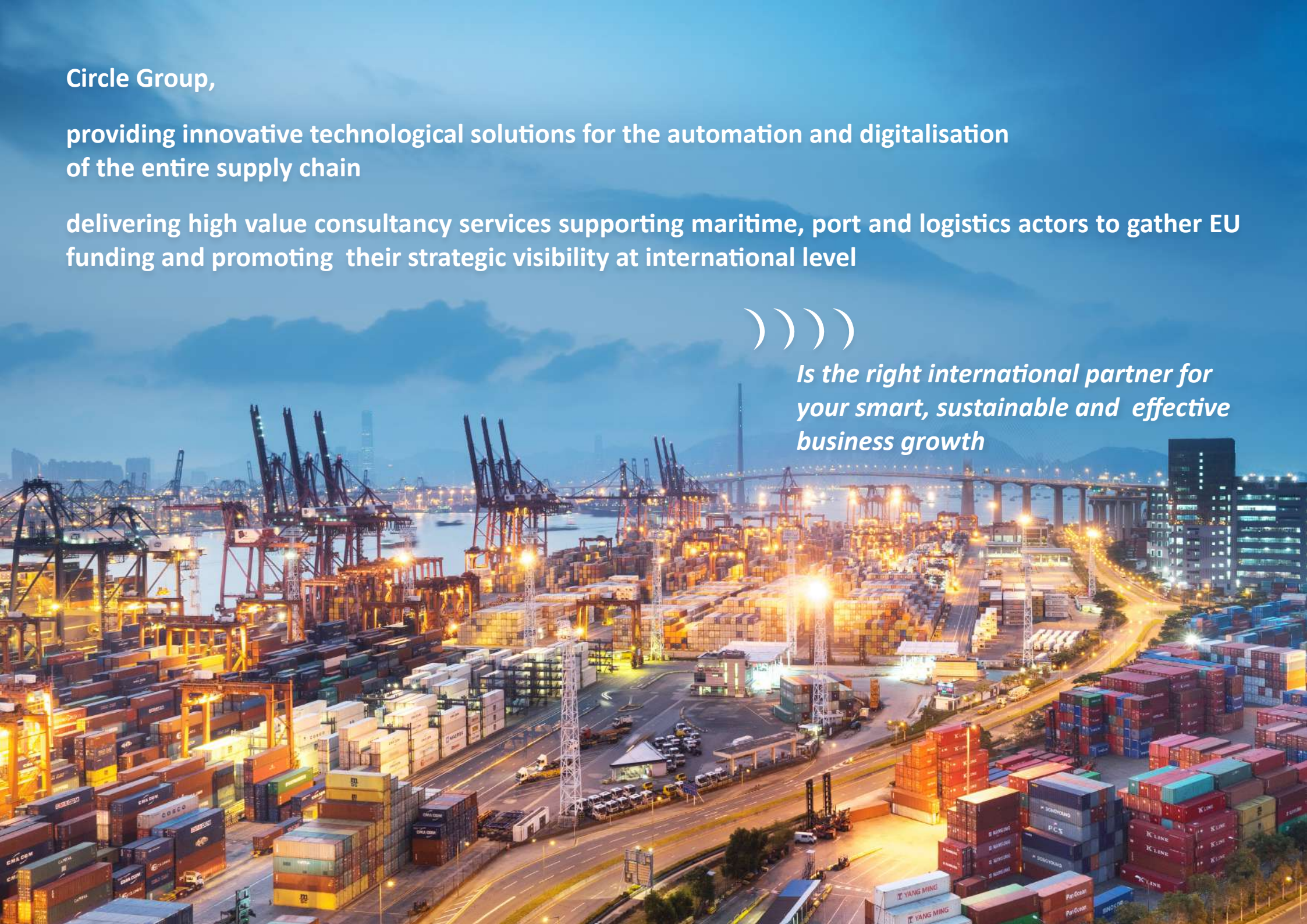



## With distinctive vertical skills in the port and intermodal logistics

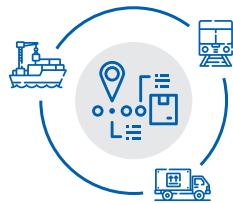

- we analyse the **international port, maritime and logistics policy framework** and the most promising **technological trends**
- **we anticipate your future needs**, providing you the best competitive advantage through innovative technological solutions based also on anticipating policy driven changes
- we deliver **advanced IT solutions / software products** for port and inland terminals, multimodal transport operators and rail companies, port authorities, port communities and shipping agencies, shippers, freight forwarders and customs operators
- we offer **highly specialised consulting** to support your business development through **European funding**
- we provide **marketing and advocacy services** aimed at strengthening your visibility and positioning in Europe and elsewhere

# Key facts

**CIRCLE GROUP**

**SUPPLY CHAIN PROJECTS**

**EUROPEAN FUNDED PROJECTS**

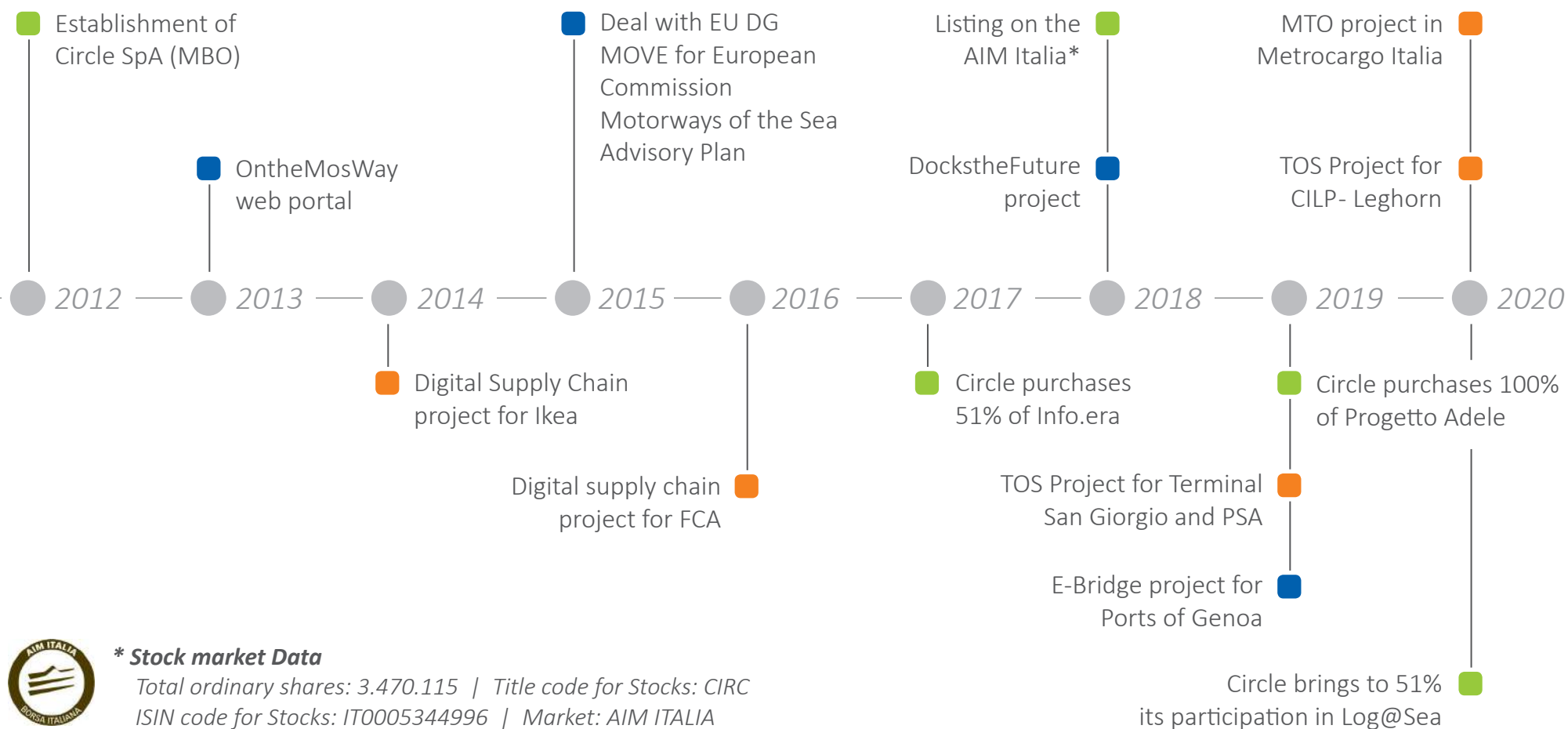

**\* Stock market Data**

Total ordinary shares: 3.470.115 | Title code for Stocks: CIRC  
ISIN code for Stocks: IT0005344996 | Market: AIM ITALIA

# Group Structure

## THE GROUP

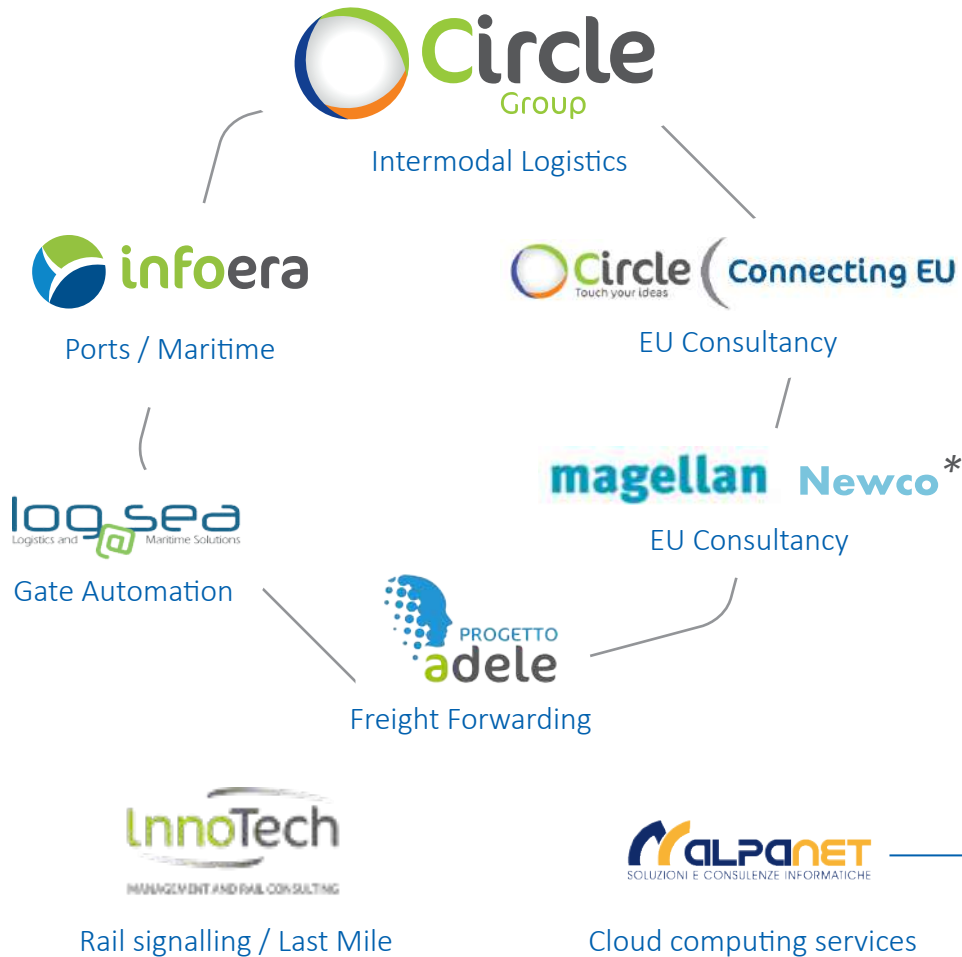

## STRATEGIC ALLIANCES



Complementary technologies / business

\*agreement signed, procedures ongoing forecasted for 31th, 2020, final closing planned before 31th January 2021

# ))))) Circle Group international coverage

## Offices

- **BELGIUM**  
Bruxelles
- **ITALY**  
Genoa | Milan | Trieste
- **PORTUGAL**  
Porto
- **TURKEY**  
Istanbul | Ankara | Mersin

## Legend

■ Covered areas

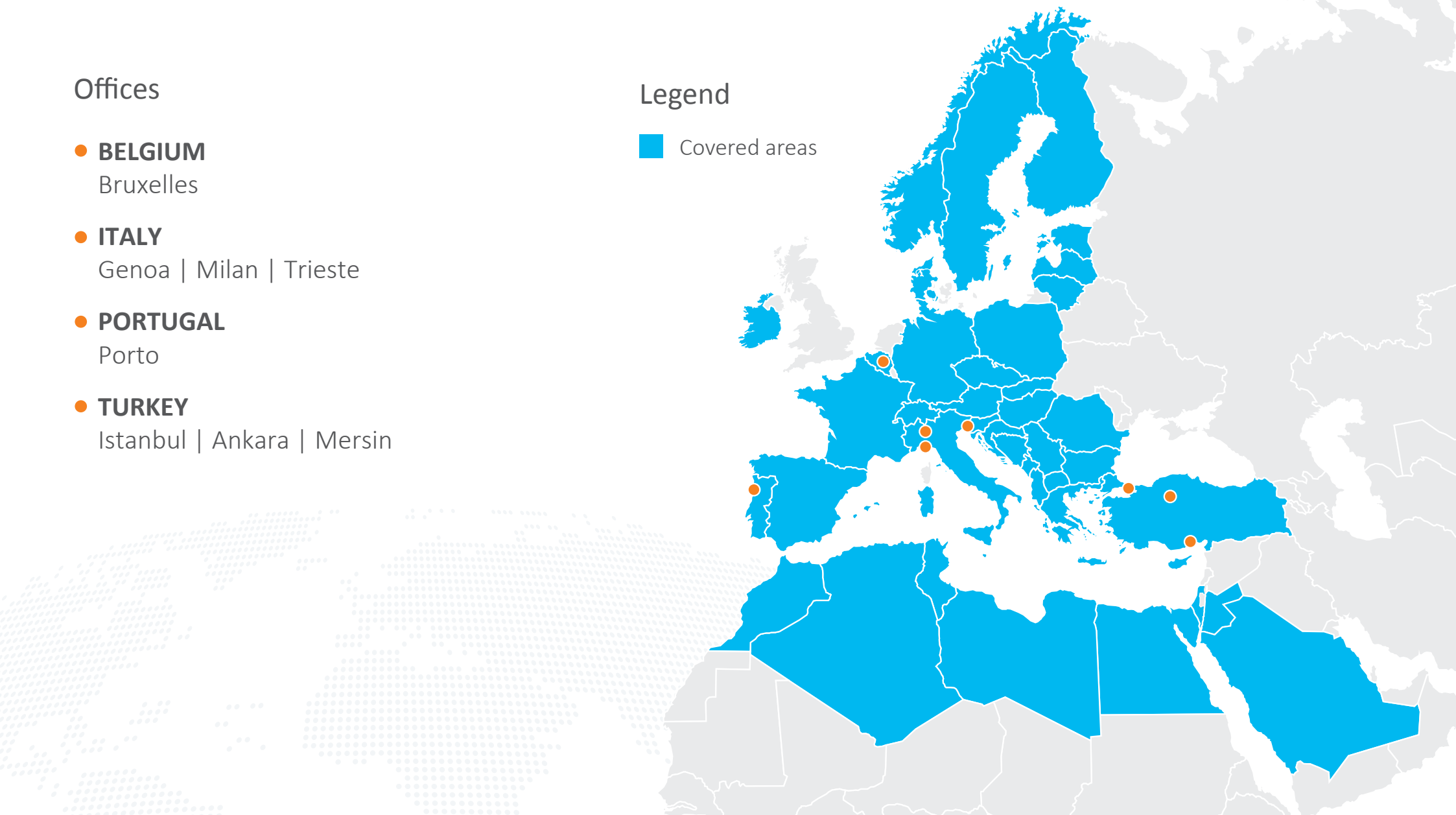

# Circle Group: 2012-2019 revenues

Circle Group | Revenues FY 2019: € 6.1 mln

+27 % vs 2018

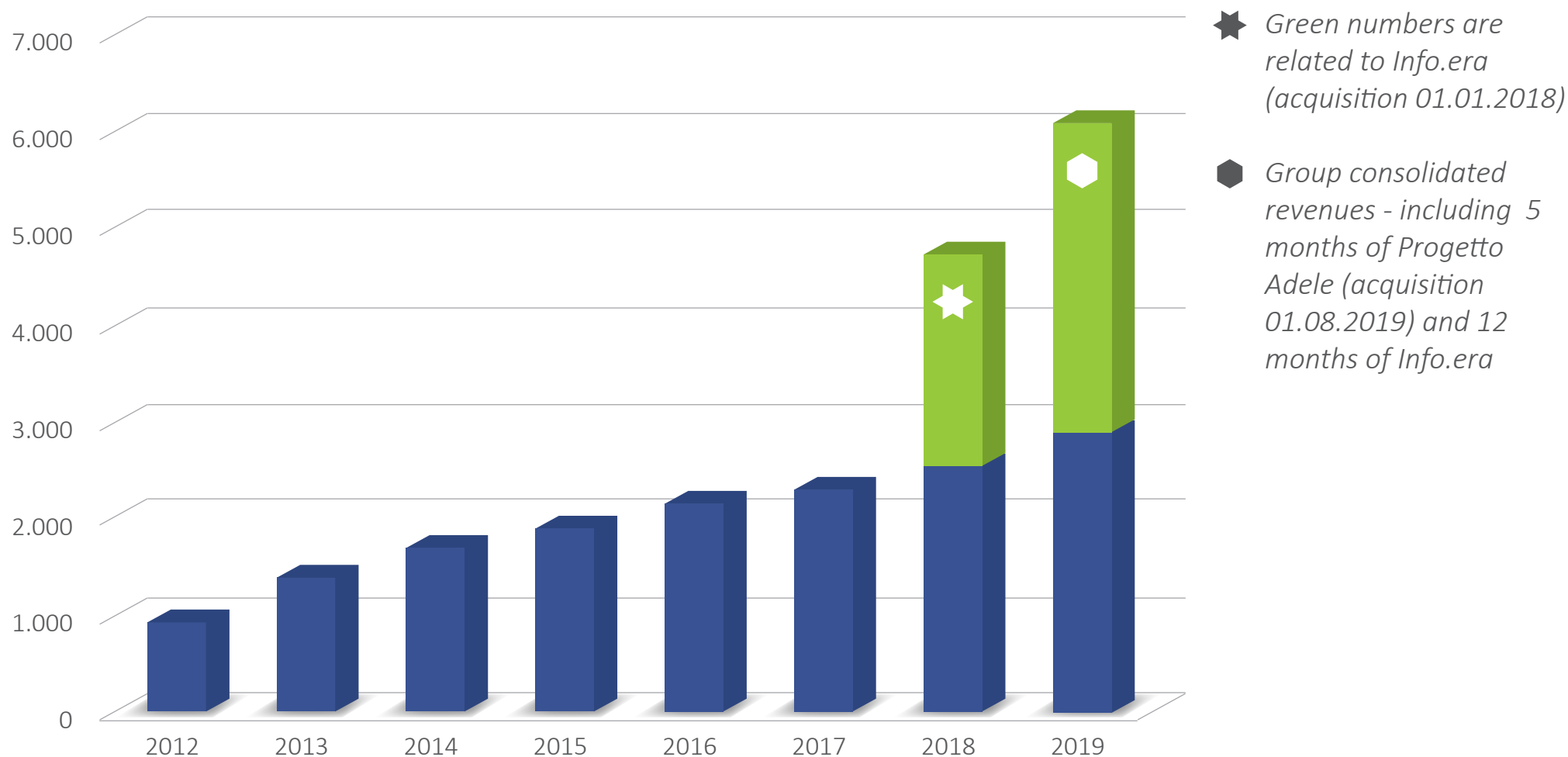

# ))) R&D and Quality certification



15% of Circle Group's budget is dedicated to **R&D and innovation projects**, with a specific focus in the application of new technologies into concrete multimodal transport projects.

Ongoing projects on **Blockchain, IoT, e-Seals, Optimisation, Digital twin, Big data & Artificial Intelligence**.

The strong cooperation between Circle Group's internal dedicated **R&D team and Academics** guarantees a relevant progress beyond the current state of the art in port and logistic concepts and **experimental technologies**.



**Circle Group has ISO 9001 Certification** defining an harmonised and uniform working and control method, ensuring the appropriate involvement of suppliers and professional partners, as well as ensuring the correct interpretation of the customers' expressed and unexpressed needs, with the aim of improving the overall quality of service.



# Business units & Lines of Business

## BUSINESS UNITS

Innovative and Smart  
Supply Chain

Global Supply Chain  
Visibility

Connecting EU

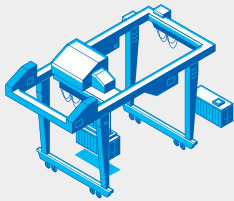

Terminal

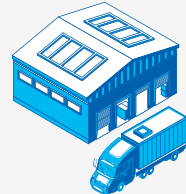

Shippers



Project Anticipation

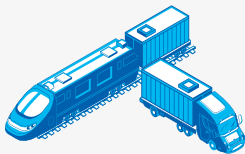

Multimodal Terminal Operators and Rail



Freight Forwarders



EU Branding

Federative & Customs solution

Optimisation

Client Projects

LINES OF BUSINESS



# ***INNOVATIVE & SMART SUPPLY CHAIN***

---

*Inland and Port Terminal Operators  
Multimodal Transport Operators & Rail companies  
Port Authorities & Port Communities  
Shipping Agencies*

# Target and Products

Inland and Port Terminal Operators

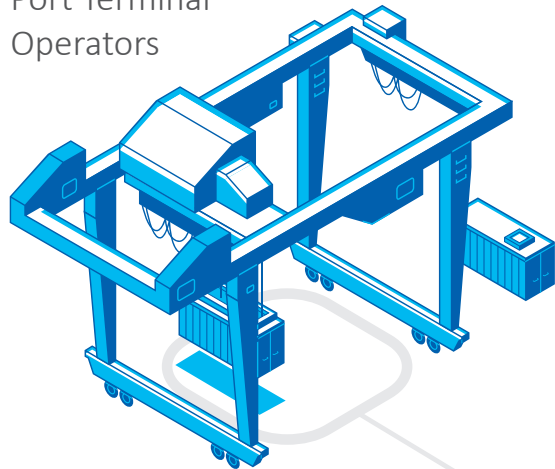

Port Authorities and Port Communities

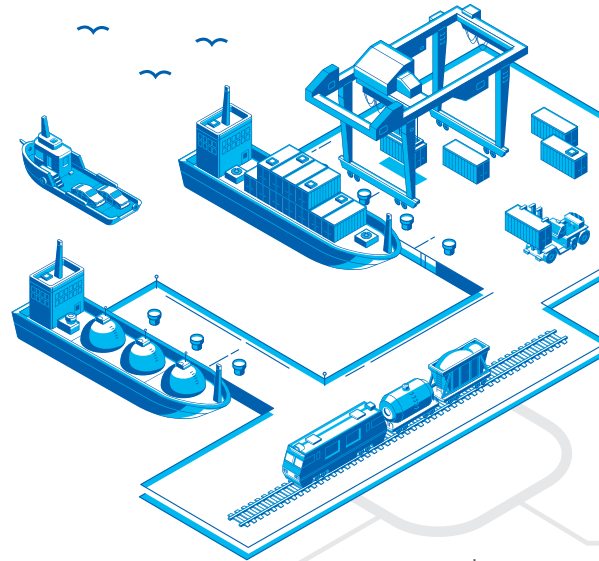

Shipping Agencies 4.0

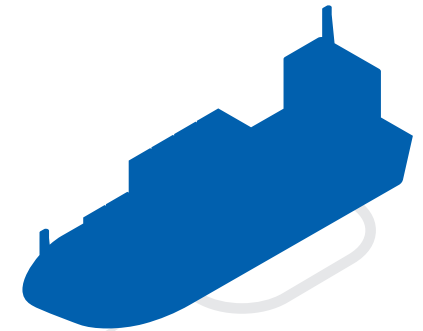

Multimodal Transport Operators & Rail Companies

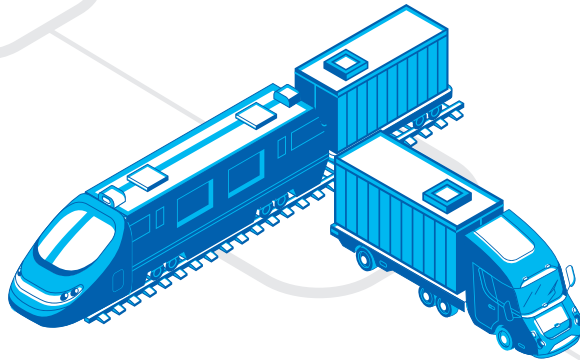

Extended PCS

**Milos-TOS**

Supply Chain Federative Services\*

**Sinfomar**

**Milos-MTO**

Supply Chain Federative Services\*

**Milos**

\*Supply Chain Federative Services, as cross-services for Innovative and Smart Supply Chain BU and Global Supply Chain Visibility BU, are outlined at slide n°28





# )))))) Target and Products

## *Inland and Port Terminal Operators*

**Milos® TOS** is a suite made up by several modules to achieve an effective global management of a multipurpose terminal throughout full digital streamlined processes and reliable federated interoperability with all the relevant stakeholder's information systems.

### **BENEFITS**

---

- *Effective control of customs and administrative operations*
- *Full interoperability with Port Community System*
- *Integrated digitalisation of Rail, Vessel, Yard and Gate activities*
- *Mobile APPs availability*
- *Optimisation of gate, equipment and HR management*
- *Higher yard & gate productivity and handling efficiency*
- *Time and costs savings*

**Milos·TOS**

# Success Case

## Compagnia Impresa Lavoratori Portuali (CILP)

### The Client

Compagnia Impresa Lavoratori Portuali (CILP) provides loading/discharging operations related to the management of the entire port operational cycle.

The multipurpose terminal in the Port of Leghorn is characterised by different areas for the stocking of various product categories: forest products (over 700.000 tons in 2019), new cars (over 305.000 units in 2019) and vehicles (over 61.000 tons in 2019), project cargo (over 4.700 tons in 2019) and containers.

### Needs & Requirements

The Multipurpose Terminal management complexity requires a global and effective handling of activities, as well as process simplification and digital interoperability with other actors of the supply chain.

### Solution

**Milos® TOS suite** allows to manage logistic, administrative and customs operations in a unique system; all the relevant information from the operators are digitally secured (PCS, Shippers, Customs Single Window, etc...) by integrating IoT smart devices (Tags, e-seals) with mature technologies (OCR). Milos® TOS allows the implementation of Gate Automation solutions to enable gate in / gate out time reduction assuring the full cargo track and trace.

### ABOUT US

#### CILP management confirmed

*«We are very satisfied of Milos® TOS and convinced that this important step towards the full digitalisation of our company can support us in the development of our business, delivering improved services with a confident glance to the future».*







# Target and Products

## Multimodal Transport Operators & Rail Companies

**Milos® MTO** suite, composed by a set of integrated and interoperable modules, is capable to manage new rail connections, customer bookings, planning and execution of rail and intermodal transport and the full invoicing cycle.

### BENEFITS

---

- *Advanced modules to boost the efficiency of transport planning*
- *Optimisation of multimodal transport operations: truck triangulation and best trucker selection*
- *Interoperability with third parties' existing supply chain platforms*
- *Improvement in decision-making and operational optimisation thanks to information visibility*





# Success Case

## *PSA Genova Prà*

### **The Client**

PSA Genova Prà is part of PSA INTERNATIONAL, one of the global leading port groups concerning container terminal activities. It has direct inland connections to continental Europe, granted by the direct connection to the national railways system and the straight access to the Italian motorway. The terminal is equipped with 15.000 TEU ground slots, 1.500 reefer plugs and a dedicated IMO park with 320 TEU ground slots.

### **Needs & Requirements**

Rail transport procedures at the terminal and all the linked activities required an optimisation. PSA needed a new model for information interoperability among all players involved in freight transport from port terminal to inland terminal of destination.

### **Solution**

Thanks to **Milos® MTO** suite the project “Railway Digitalisation” was carried out for PSA Genova Prà with the optimisation of rail transport and procedures. This Milos® suite allows to manage bookings and priorities, to schedule in an integrated way import/export of trains, to produce the related needed documentation, as well as the reporting for administrative purposes also accessible via mobile.





# Target and Solutions

## Port Authorities & Port Communities

Our **Extended Port Community System Sinfomar®** is developed to act as a one stop shop to digitally connect public and private actors, effectively implementing port community processes. Including operators from Customs Authority to Coast Guard, from shippers to transport providers and MTOs, from last mile logistic operators to shunting companies, from railway undertakings to inland terminals, Sinfomar® allows the improvement of efficiency and fluidity of traffics from/to the ports and, at the same time, it represents an important control and monitoring tool.

### BENEFITS

- *Full digital management of cargo and vehicles handling*
- *Efficiency and fluidity of transport flows from/to the ports*
- *Faster administrative & bureaucratic procedures*
- *Immediate real-time validation / clearance by competent public authorities*
- *Federated approach & interoperability with different networks of ICT systems*

 **Sinfomar**

# Success Case

## *Port of Trieste*

### **The Client**

Trieste Port areas are composed of “Porto Vecchio”, “Porto Nuovo”, “Scalo Legnami” and “Zona Industriale” (characterised by total or partial areas of Free Zone, i.e. “Punto Franco”). The port areas are furthermore divided into common areas (managed by “Port Authority System of the Eastern Adriatic Sea”) and areas under concession (managed by terminals and private operators), including the dry port of Ferneti.

### **Needs & Requirements**

The improvement of the competitive position of the ports’ community was required, providing effective tools to manage all administrative, operative, tax and customs procedures related to port logistics in a streamlined and full digital way through joint standards capable of optimising the information flows and the interoperability between various stakeholders.

### **Solution**

**Sinfomar®** is the extended platform that enables intelligent and secure exchange of information between public and private operators and logistic actors in order to optimise, manage and automate port and logistics processes through a single submission of data.

Sinfomar® is composed by modules and connectors for the full digitalisation of port, administrative and customs operations, including shunting, last mile rail operations and trade corridor management.





# Optimisation

*Crosswise & added value tools*

The Optimisation Tools are decision support systems used to simulate a more efficient management of a specific set of transport operations.

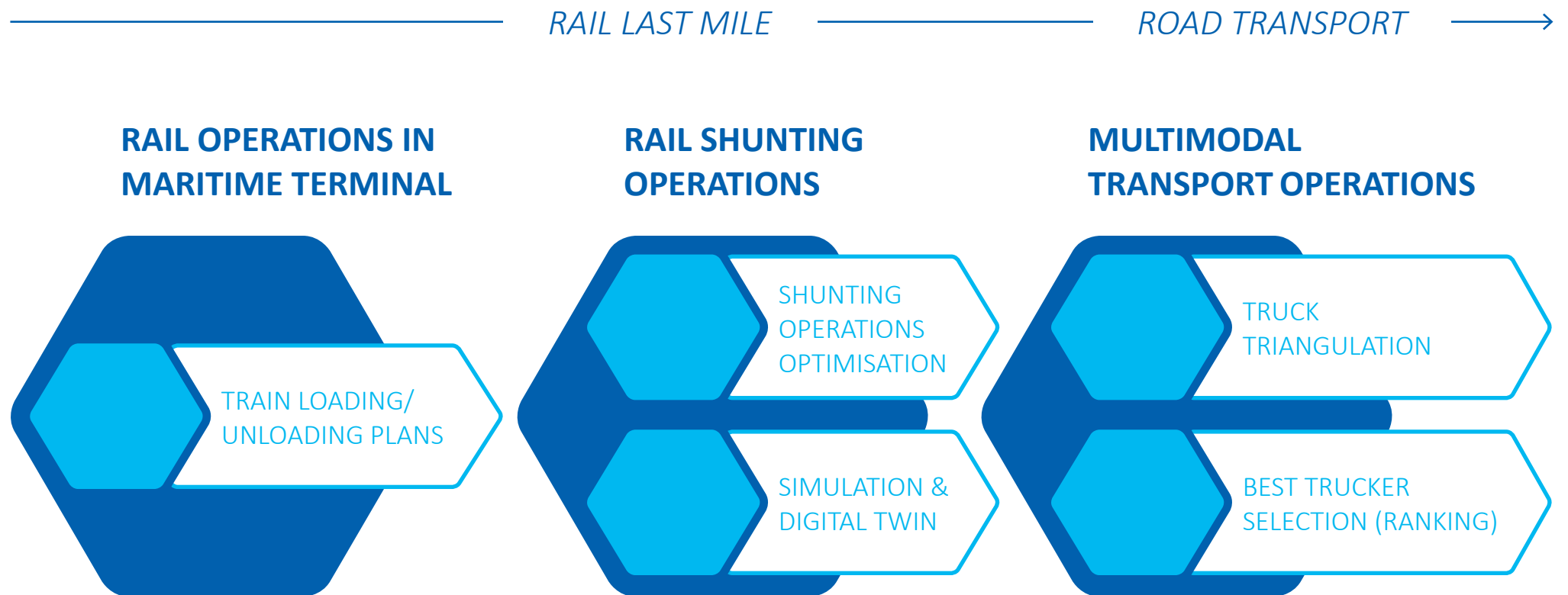



# ***GLOBAL SUPPLY CHAIN VISIBILITY***

---

*Shippers  
Freight Forwarders  
Customs Operators*

# Target and Products

Shippers

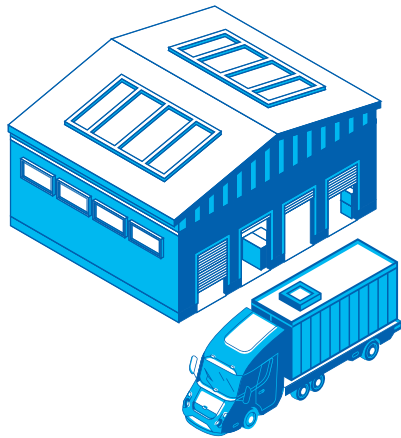

Freight Forwarders

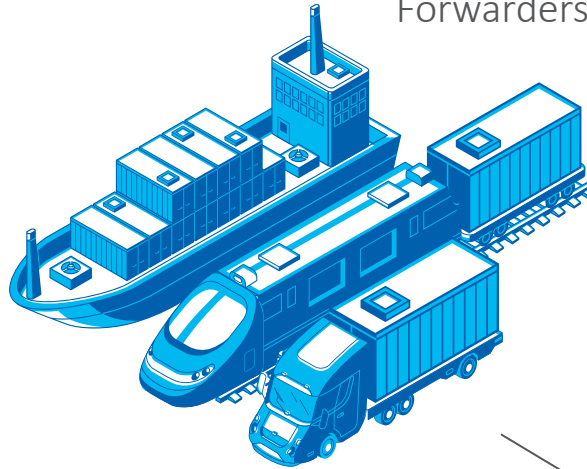

Customs Operators



*Evolutive platform*



**Supply Chain  
Federative Services\***



**Supply Chain  
Federative Services\***

*\*Supply Chain Federative Services, as cross-services for Innovative and Smart Supply Chain BU and Global Supply Chain Visibility BU, are outlined at slide n°28*



# )))))) Target and Products

## Shippers



**Milos® Global Supply Chain Visibility** is an innovative modular suite designed to meet the need of shippers to get visibility of all the information shared by actors involved in the supply chain by using an interactive dashboard called Corridor Management Platform.

### BENEFITS

---

- *Immediate and simplified access to services offered by different carriers / shipping companies worldwide through a specific connector, reducing time and cost*
- *Reduction of manual errors and speed boost for shared documentation thanks to the digitalisation of the information flow*
- *Fully digital Track and Trace of containers' flows thanks to Milos® PLN (National Logistic Platform) connector*
- *Management of cost / invoice process and KPI dashboard creation thanks to the integration with customers' ERP systems*
- *Security guarantees thanks to the integration of new technologies and digital tools (IoT, Blockchain, Digital Twin, AI) to create information flows with control of operations and events occurring within the logistic chain*



# Success Case

Ikea

## Client and requirements

Ikea has a logistic hub in Piacenza (Italy), to which goods arrive from all over the world addressed to stores based in Italy, North Med and Middle East. The issue concerned the Customs clearance process of goods coming from Extra EU countries: it started with the containers dischargement at the port, heavily affecting goods' arrival time at the logistics hub of Piacenza.

## Solution

Thanks to its connectors, **Milos® Global Supply Chain Visibility** suite makes available real time information from Port, Customs and National Logistic Platform concerning status and positioning of goods, Customs clearance and security information. This overall view of the shipment is available on a comprehensive dashboard. Moreover, thanks to Customs Corridors (Italian "Fast Corridor"), goods in import (container) are customs cleared directly at the logistic hub, with no stop at the time of disembark and goods in export (container) receive the authorisation for customs procedures before arriving at the port.

## Key facts of the project

The main KPI's index (provided by IKEA) are a direct cost reduction per teu of -30%, a paper reduction of -100% and a shipped container's volume increased over 80% thanks to Customs Corridor. The main KPI's index concerning Supply Chain players involved are a transit time reduction port- dry port up to 35% and a dwell time reduction (due to various aspects, among which customs) up to 80%.



# )))))) Pilot Project

## *International Fast & Secure Trade Lane Tarros & Terminal del Golfo*

### **The Client**

Through its Network, Tarros Group is able to offer a personalised service to customers and, since 1828 has based its development on innovation, passion and respect for the territory where Group's Companies are established. Thanks to its 610 employees, Tarros Group connects every day the different shores of the Mediterranean, 16 countries, 31 ports and over 450 million people while offering an efficient and modular system at all stages of transport chain.

### **Need and requirements**

The digitalisation of port and logistic nodes is the key point for the development of a fast and secure multimodal logistic chain: this means the need of creating digitalised documental flows able to allow significant advantage in terms of goods managed, procedures speed up and traffic boost.

### **Solution**

**The International Fast & Secure Trade Lane pilot project** concerns the door-to-door link among La Spezia and Casablanca ports, within the European Project "FENIX - A European Federated Network of Information eXchange in LogistiXStudy". The Project aims at optimising maritime, logistic and transport processes, simplifying and integrating information flows thanks also to the use of Internet of Things (IOT) and at standardising and digitalising documental flows among the different players involved (using «Notarisation», Document Process Automation and Artificial Intelligence).







# )))))) Target and Products

## *Freight Forwarders & Customs Operators*

**MasterSPED®** is the evolutive platform developed specifically for Freight Forwarders and Customs Operators, integrated with goods' Tracking systems (using also IoT devices) and with intermodal transport informative systems (air, rail, road, maritime). MasterSPED®, thanks also to the integration with Milos®, allows great recovery of efficiency, reduction of costs and increasing of performances as required by major international importers and exporters.

### **BENEFITS**

---

- *Evolved import port procedures*
- *International Fast & Secure Trade Lane and integration with Internet of Things*
- *Single Windows (Su.Do.Co)*
- *Intermodal Integration for Multimodal Transport Operator*
- *Port Community System integration with port security, pre arrival and fast gate*
- *Intermodal Optimisation*
- *Simplified export procedures*



# Success Case

*GDT Logistic*

## Client and requirements

GDT Logistic is an international forwarding agency operating in food, chemical, plant and textile sector. Furthermore it is a C.A.D. (Customs Assistance Center) and A.E.O. (Authorized Economic Operator). The preparation of Customs documents in name and on behalf of customers is an activity that requires the interaction with different parties with consequent increasing of costs and reduction of process efficiency. The challenge was the definition of a new process management and the optimisation of Customs operations.

## Solution

The implementation of a new application of **MasterSPED®** platform provides the automation and optimisation of information and documentation flows. Thanks to the new “Bill Listener” application, it’s possible to get the complete digitalisation of customs documents received from the various parties involved, centralising the main functions on a single dashboard.

## Benefits

- Real time management of customs flows
- Real-time control and management of supplier work
- Increased efficiency of internal document management
- Time reduction of over 40% within the process
- Reduction of manual errors up to 80%



# Federative & Customs services

## *Crosswise & added value services*

**Milos® Federative & Customs Services** (Customs Registers, e-Manifest etc.) is a set of tools and services enabling easy and up-to-date interoperability among different actors of the logistic chain and customs processes.

These services allow to share customs information between the parties involved in the import/export process, guaranteeing data security and reliability. The integration with the latest services provided by national Customs (consistent with EU e-Customs 2025 Plan) makes the most advanced tools available to Shippers, Freight Forwarders, Carriers and MTOs.



### **BENEFITS**

---

- *Overall control of data and information*
- *Improvement of the logistic process in terms of service quality and security level (avoiding frauds and manual errors)*
- *Security and operative costs reduction*
- *Transit and dwell time reduction*
- *Environmental positive impacts*





# )))))) Federative Services

## Digital transformation is rapidly changing the global supply chain

Every day transport and logistics operators need to adapt their operations connecting their systems with an everchanging number of actors and solutions.

**Circle Group Federative Services enable quick and simple interoperability between existing intermodal supply chain platforms**, improving decision-making efficiency and operational optimisation.

By using customised connectors, the legacy systems can easily and automatically dialogue with the surrounding logistics environment, effectively integrating the information made available by the connected third parties' systems.

- Cost and time reduction
- Reliable, secure and updated data, avoiding manual errors
- Positive environmental impacts
- Availability of “smart systems” with proactive decision-making support (i.e. notarisation)
- Compliancy with data management policies

# Federative Services - overview

## TARGETS

Shippers



Multimodal Transport Operators and Rail Companies



Freight Forwarders and Customs Operators



Port and Inland Terminals

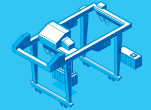

● Rail Track & Trace

● Edifact / Ediges engine

● Booking regarding intermodal rail transport

● Interchange Notarization

● International Fast & Secure Trade Lane

● International Fast & Secure Trade Lane

● Notarisation train wagon LDV

● Notarisation train wagon LDV

● Asset tracking

● Notarization - customs security document for SUDOCO

● IOT for terminal gate automation

● Semantic digital process automation

● Rail & Intermodal connector

● Best trucker selection

● Truck last mile & intermodal triangulation

● Green report

● Truck smart gate

● Federative Services: list & target

● International Fast & Secure Trade Lane

● Edifact / Ediges engine

● Asset tracking

● H30 / intermodal pre announcement / inland

FEDERATIVE SERVICES

● Ongoing development

● Available services

# Use Cases

## *Notarisation & Blockchain applied to eCustoms*

### The Challenge

The objective is to support the process of “validation and certification” of documents with a customs and security value throughout the entire logistic process, following the industry needs concerning also the Customs 2020 - 2025 evolutive procedures. This aim is achievable using “notarisation” and new technologies based on distributed registers.

### Solution

The **Notarisation & Blockchain applied to eCustoms** is the solution for the complete management of documentary flows in “ONCE” approach for the subsequent phases of customs verification. It is integrated within Milos® Global Supply Chain Visibility Suite which allows the entire handling process to be coordinated among private players and along the international chains (maritime, port and intermodal logistics).

### Pilot Project

- International Fast and Secure Trade Lane (with IoT)
- Rail cargo document/CIM notarisation (with blockchain)
- Interchange Notarisation





# Client projects

## *Crosswise & added value hub*

“**Client projects**” is the hub dedicated to the development of customised supply chain projects, specifically built on clients’ needs. Thanks to know how in business process reengineering, together with the strong skills in supply chain software development, Circle Group can support the client in the path to digitalisation and dematerialisation of business processes.

### **BENEFITS**

---

- *Improved efficiency in the management of business processes*
- *Compliancy with the updates of the legal framework*
- *Exploitation of benefits coming from grants dedicated to digitalisation and green transition*



# ***CONNECTING EU***

---

*Funding EU opportunities  
and boosting European business*

# Target and Services

## Connecting EU

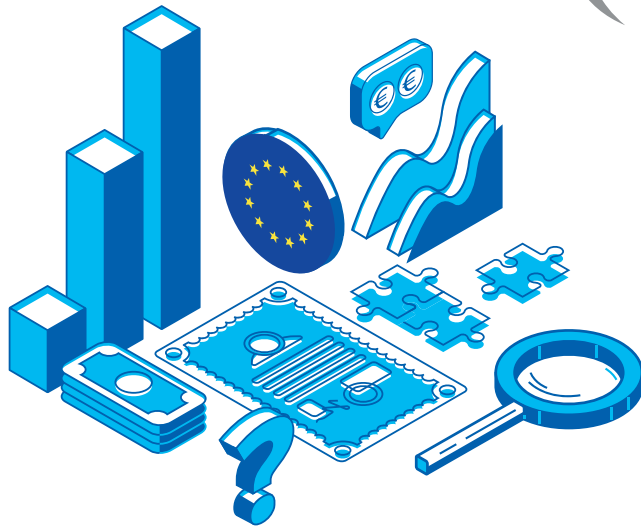

Project Anticipation



EU Branding

supporting  
Public and Private entities in business development  
through international visibility and EU funds





# Target and Services

## *Project Anticipation*

Project Anticipation services aim at supporting Public Authorities and private companies in achieving their strategic objectives through European funding thanks to our in-depth knowledge of transport policies and actors and the relevant experience in EU projects generation, negotiation and management.

### OBJECTIVES

---

- *Fund your innovative projects*
- *Achieve your business development goals*
- *Forecast policy and technological trends*
- *Find new business partners*
- *Increase credibility in new areas*
- *Maintain high competitiveness*

### SERVICES

---

- *Multiannual project support for funding schemes*
- *Programme scouting, proposal preparation, contract negotiation*
- *Advanced project management & business development support*
- *Consultancy on policy making*
- *Advocacy in Brussels*

# Success Case

*A selection of projects we led during the last few years*



## EUROPEAN PROJECT

Circle is the leading partner of the DocksTheFuture Project, defining the vision for the ports of the future, covering specific issues such as emission reduction, energy transition, electrification, port-city interface and the use of renewable energy management. Furthermore Circle is in charge of the creation of the Network of Excellence, gathering the most innovative ports willing to team up and take actions to support the maritime community achieving the UN 2030 Sustainable Development Goals.



## CONSULTANCY

Circle is the leading consultant entity supporting the European Coordinator for Motorways of the Sea since 2016 (contract renewed till 2022) in the definition of the Detailed Implementation Plan for MoS, setting the future policies guidelines for maritime activities inside the European Transport Network.



# Target and Services

## EU Branding

EU Branding services aim at designing innovative tools for the positioning on the international market of companies specialised in port, transport and logistics, implementing specific marketing and communication actions, and business events, to strengthen relations and business proposals in Europe.

### OBJECTIVES

- *Promote your best practices to the European port & shipping community*
- *Support you entering the international market*
- *Boost your relations in Brussels*
- *Market your products and services toward a highly targeted audience*
- *Help you in finding your next clients and partners through matchmaking service*

### SERVICES

- *Digital and Social multichannel promotion (direct e-mail marketing, press activity, LinkedIn profile and websites)*
- *Organisation of conferences & expo, workshops and seminars, hybrid and virtual events (webinars, video interviews, live streaming, video pills, virtual conference)*
- *Business to business matching service*



# Success Case

*A selection of projects we led during the last few years*



## **PHYSICAL EVENTS with a network of around 2.000 attendees:**

- Motorways of the Sea Forum (2016, 2017, 2018, 2019, 2020) concerning maritime policy and financing opportunities
- BILOG- Logistics and Maritime Forum 2017, 2019, 2021 (ongoing) concerning EU Transport Policy and investments on the entire logistic chain
- DocksTheFuture Midterm Conference 2019 concerning the vision for the ports of the future

## **VIRTUAL EVENTS (Webinars and workshops)**

- The European Green Deal. Opportunities for the transport and logistics sectors (2020)
- Confucius' suitcase. China - EU freight train after Covid-19: updates & prospects (2020)
- The sustainability of human capital in the logistics of the future (2020)



# VISION FOR THE FUTURE

---

We work continuously on **improving processes and solutions** to increase optimisation in line with always changing trends in the **world of maritime trade and logistics.**

# Product evolution

2021-2024 roadmap

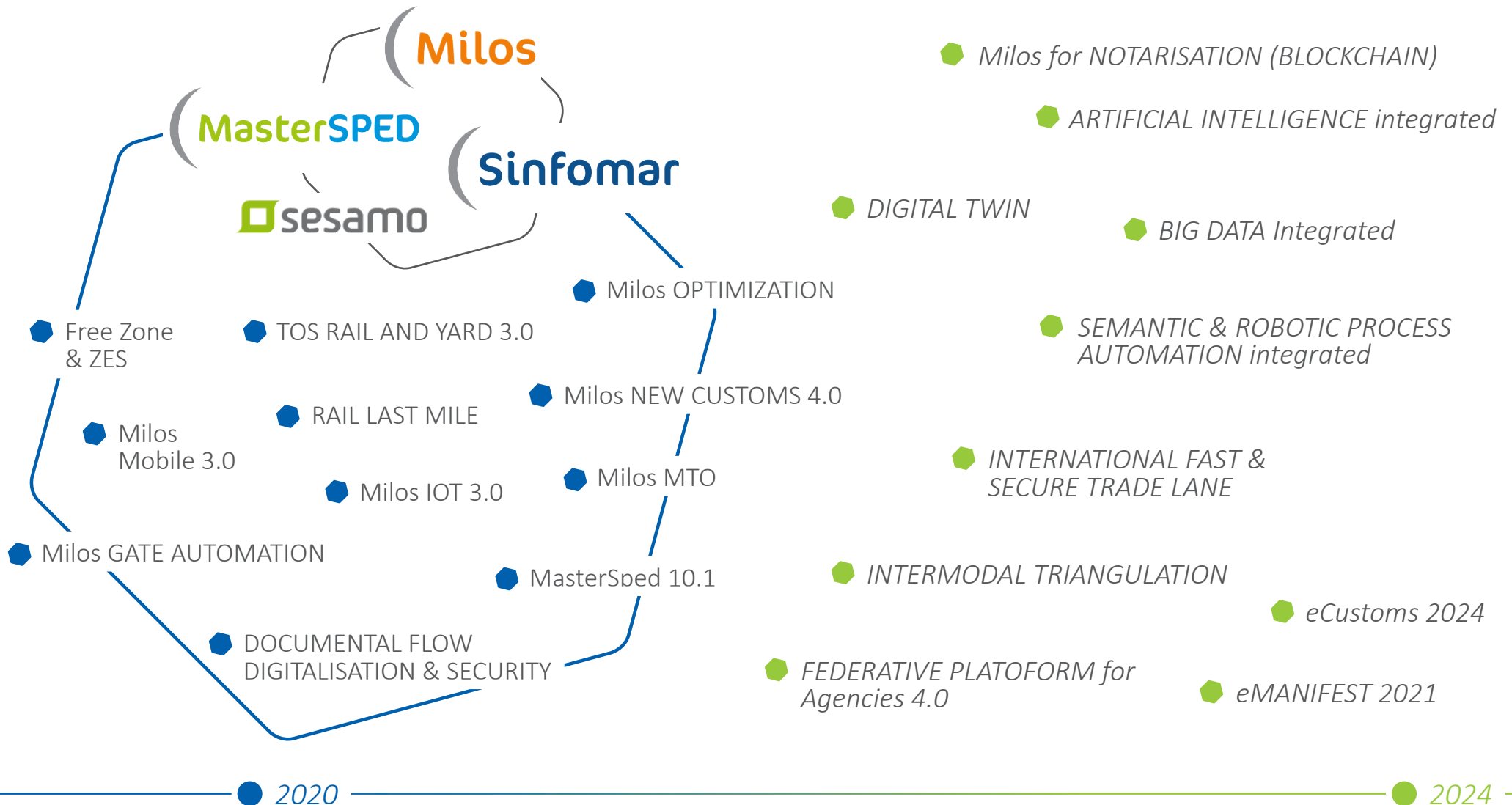



# EU services evolution

2021-2024 roadmap

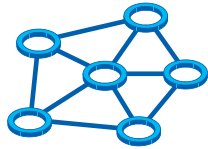

## Docks the Future Network of Excellence

Exploitation of **Docks the Future Network of Excellence (NoE)**, launched in 2020 with the most innovative European ports (currently 17), aiming at achieving the port of the future related **EU Green Deal** targets by:

- *promoting best practices and digital transformation*
- *implementing co-funded projects and supporting policy changes*
- *fostering the dialogue among international organisations*



## Advocacy and international presence

Strengthening of EU advocacy through:

- *the reinforcement of the **Brussels Office***
- *the presence in other **EU Mediterranean countries** (M&A)*

to consolidate the market positioning of the EU Projects Anticipation and EU Branding services



## Next Generation EU

Exploitation of «**Next Generation EU**» funds dedicated to green, digital and resilient Europe (research and innovation and digital transitions) through:

- *the well established **Connecting EU Network of partners***
- *the reinforced international presence*

# Geographical expansion

*International activities and projects*

## Legend

- *Ongoing projects*
- *Ongoing preliminary project proposals and lead generation activities*
- *Target countries for additional developments*
- *Clients / Projects*

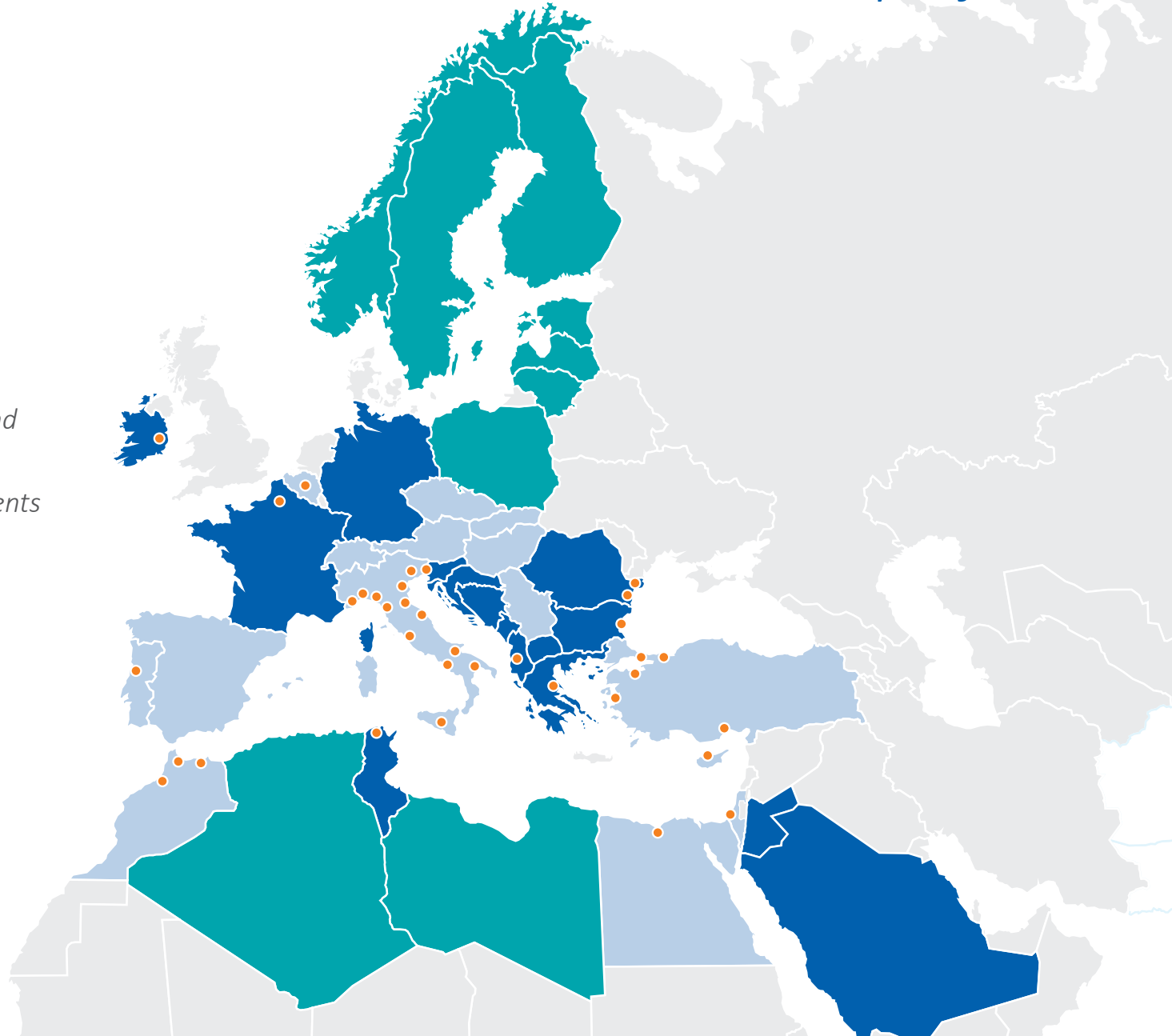

# Contacts

## Genoa

Via Bombrini 13/3  
16149 Genova- ITALY  
info@circletouch.eu

## Trieste

Via San Nicolò 4  
34121 Trieste- ITALY  
info@circletouch.eu

## Milan

Via Fara Gustavo 28  
20124 Milan- ITALY  
info@circletouch.eu

## Brussel

circlebelgium@circletouch.eu

## Porto

circleportugal@circletouch.eu

## Istanbul

turkey@circletouch.eu

## Mersin

turkey@circletouch.eu

## Ankara

turkey@circletouch.eu

## Balkan Region

balkans@circletouch.eu

## Maghreb Region

maghreb@circletouch.eu

## Arabian Region

circlearabia@circletouch.eu

 [www.circletouch.eu](http://www.circletouch.eu)

 Circle Group

 Circle

